

Introduction: R580, R5880

Designed for surface mount applications, this high capacity series of architectural grilles provide an air stream that can be fully adjusted from a concentrated jet to a robust, widespread air pattern.

MODELS

R580 - Aluminum, Round Single Deflection, Concealed Mount

R5880 - Aluminum, Round Double Deflection, Concealed Mount

FEATURES

- Aluminum construction.
- Round single (R580) or double (R5880) deflection airfoil blade grille with 1" blade spacing.
- Easy finger tip adjustment.
- For use in surface mount applications.
- Flex duct mounting frame available.
- Concealed mounting system standard.

FINISHES

- Standard finish is #70 Silver Metallic.
- Optional finishes available.



R5880 (Face & Side View)



R580, R5880 Dimensional Information

R580, FACE AND SIDE VIEWS

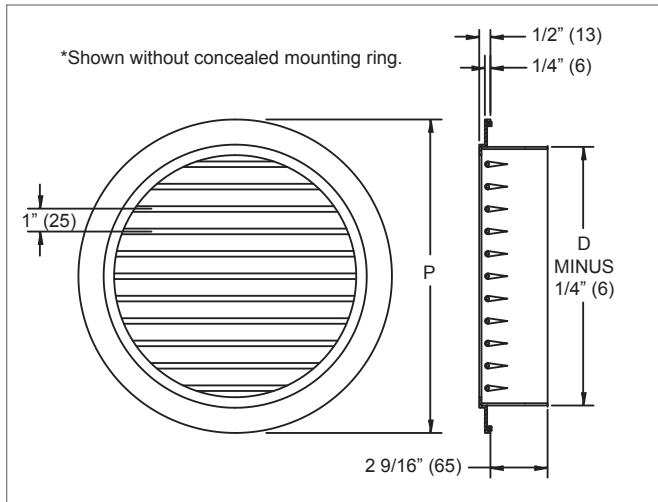

R5880, FACE AND SIDE VIEWS

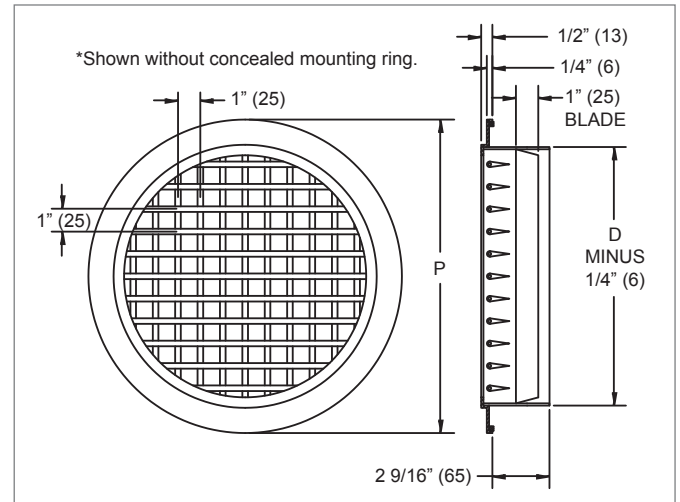

R580, DIMENSIONAL DETAILS

Nominal Size	Duct D	P
6	6" (152)	8 1/4" (210)
8	8" (203)	10 1/4" (260)
10	10" (254)	12 1/4" (311)
12	12" (305)	14 1/4" (362)
14	14" (356)	16 1/4" (413)
16	16" (406)	18 1/4" (464)
18	18" (457)	20 1/4" (514)
20	20" (508)	22 1/4" (565)
22	22" (559)	24 1/4" (616)
24	24" (610)	26 1/4" (667)

R5880, DIMENSIONAL DETAILS

Nominal Size	Duct D	P
6	6" (152)	8 1/4" (210)
8	8" (203)	10 1/4" (260)
10	10" (254)	12 1/4" (311)
12	12" (305)	14 1/4" (362)
14	14" (356)	16 1/4" (413)
16	16" (406)	18 1/4" (464)
18	18" (457)	20 1/4" (514)
20	20" (508)	22 1/4" (565)
22	22" (559)	24 1/4" (616)
24	24" (610)	26 1/4" (667)

NOTE: Dimensions in parentheses are mm.